

METER-RITE®

Pole-Top Double-Throw Switch
 Catalog Numbers **9800-6 & 9808-6**
 600 Vac
 NEMA 3R Rainproof Enclosure

Schematic for Catalog Numbers
 9800-6 & 9808-6

RONK ELECTRICAL INDUSTRIES, INC.
 NOKOMIS, ILLINOIS

Drawing Number

2-4155

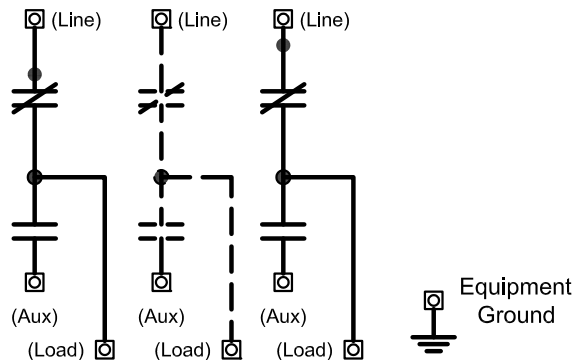
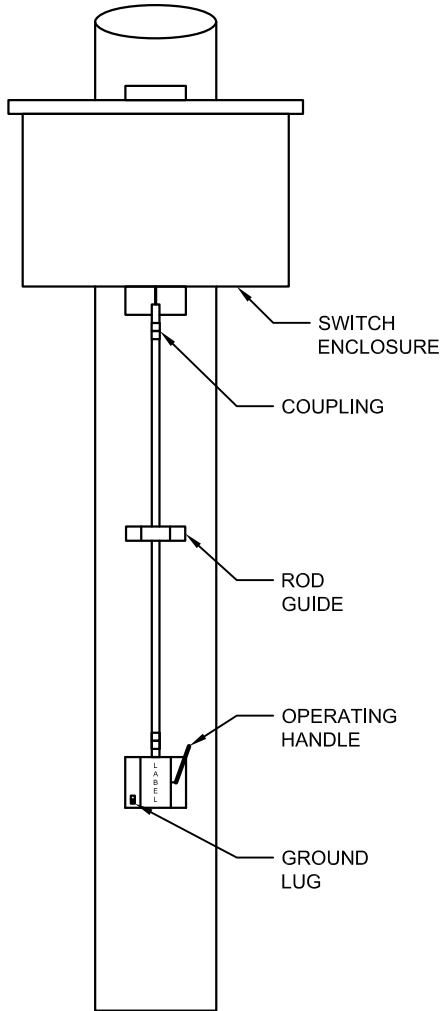

CONNECTING INSTRUCTIONS

1. Mount the switch near the top of the pole.
2. 1/2" inch EMT is recommended for connecting rod between the switch and the operating handle. Attach the desired length of EMT to the stub protruding from bottom of switch enclosure, but do not attach handle assembly.
3. Pull on rod to operate switch to LINE position.
4. Note LINE - AUX position of handle. Place handle in LINE position and insert handle stub into coupling at bottom of rod without tightening the set screw. Orient handle assembly for alignment with rod with mounting holes against pole. Tighten set screw on coupling, locking handle assembly to rod. Fasten handle assembly to pole, locating its position on the pole with rod hanging freely against stops in switch enclosure.
5. Operate handle to make sure switch is functioning. Switch should snap open and closed as handle is operated. Ground handle and enclosure using ground lugs provided.
6. Fasten U shaped rod guide over operating rod about half way between handle and switch enclosure. Rod guide should depress rod slightly toward pole.
7. Incoming lines should be connected to LINE terminals. Load lines should be connected to LOAD terminals. Standby generator may be connected to AUX terminals.

CATALOG NUMBER	PHASE	AMPS	WIRE RANGE	
			LINE AND LOAD LUGS	AUX LUGS
9800-6	3Ø	200	250 MCM - #6 CU-AL (1-HOLE LUG)	
9808-6	3Ø	400	(2) 250 MCM-1/0 or (1) 600 MCM - #4 CU-AL (1-HOLE LUG)	

TIGHTENING TORQUE	
SOCKET SIZE (INCH)	TORQUE (IN-LB)
1/8	45
5/32	100
3/16	120
7/32	150
1/4	200
5/16	250
3/8	375
1/2	500
9/16	600

USE COPPER OR ALUMINUM WIRE RATED 75° C. OXIDE INHIBITING COMPOUND IS RECOMMENDED FOR ALUMINUM WIRE.

WIRE BENDING SPACE IN THE ENCLOSURE BASED ON (2) 250 MCM, NOT (1) 600 MCM.

WARNING: ALL ADJUSTMENTS ON SWITCH HAVE BEEN MADE AT FACTORY AND MUST NOT BE CHANGED IN THE FIELD. IF SWITCH DOES NOT OPERATE PROPERLY CHECK THE HANDLE INSTALLATION ON POLE-TOP UNIT.

Revision Description
 Removed obsolete Catalog Numbers.

Rev CN
 Date 03/09/21
 BY NCL

B